

Line-Sensor

Extend Sensor Faucet FFAS8507-D00500BC0

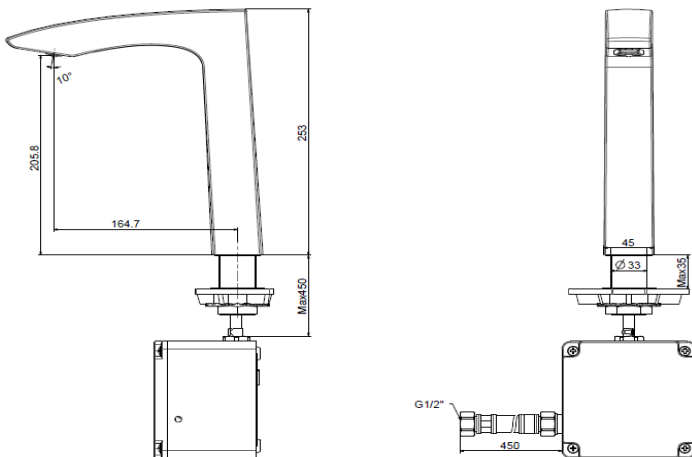

DIMENSIONAL DRAWING



FEATURES

- A grade brass, strong and durable
- DC 6V (4 pcs AA Alkaline Battery)
- With normal packaging
- Line sensor technological innovation , no error operation when the sensor face to the mirror
- $\leq 8\text{L/Min}$ at 1 bar

SPECIFICATIONS

- Sensor installed at the spou
- Faucet Reach: 164.7mm
- Faucet Height: 205.8mm

FINISHES AVAILABILITY

- Chrome (- CP)

AWARDS WON

- N/A

SHIPPING WEIGHT

- Product net weight: 3.62 kg/set
- Product gross weight: 3.8kg/set

STANDARDS CRITERIA

- CJ194-2014

Flow rate chart

