

Exposed EasySET

American Standard

Shower Auto Temperature Mixer with Integrated Rain shower Kit

A-6110-978-908AT

FFAS4955-701500BT0



DIMENSIONAL DRAWING

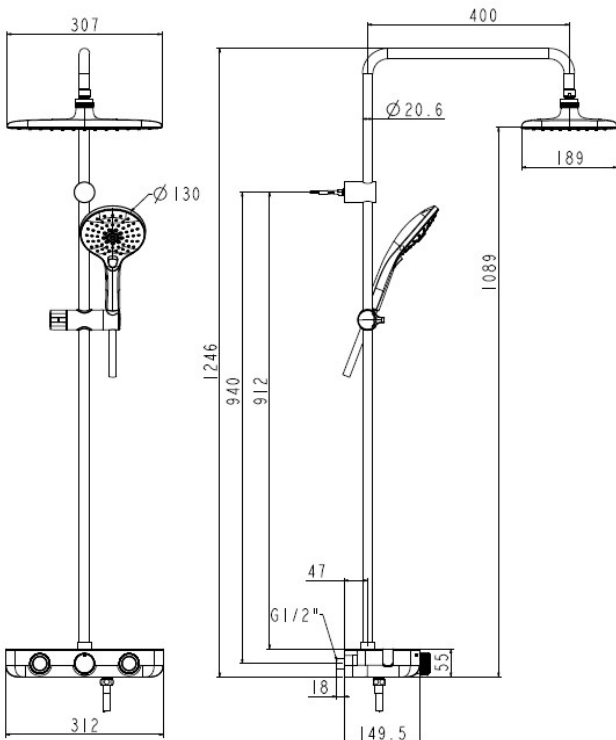

FEATURES

- German thermostatic cartridge
- Anti-scald safestop button
- Push button cartridge with flow rate adjustable from Japan, life cycle $\geq 300,000$ times
- Plastic body with cool touch design, no risk of scalding on the body
- Designed with a shelf space for storage function
- Side Hook on both side, as a shower accessories and drain the water on the top of the surface
- 3-functions Rain Click hand shower, instinctive button for switching between spray modes
- PVC Silver twist Free shower hose
- With easy glide shower holder
- With normal packaging
- 307*189 rectangle head shower, with air-in function
- Flow rate @ 0.1MPa: 4.3 L/M for hand shower
- Flow rate @ 0.1MPa: 6 L/M for shower head

SPECIFICATIONS

- Exposed THM mixer faucet
- Two-Hole Installation

FINISHES AVAILABILITY

- Chrome (- CP)

AWARDS WON

- N/A

SHIPPING WEIGHT

- Product gross weight: 8.8 kg /set
- Product net weight: 6.9 kg /set

STANDARDS CRITERIA

- GB/T 2806-2017