

Signature

American Standard

Exposed Bath & Shower mixer with
integrated Rainshower kit
FFAS1772-701500BC0



DIMENSIONAL DRAWING

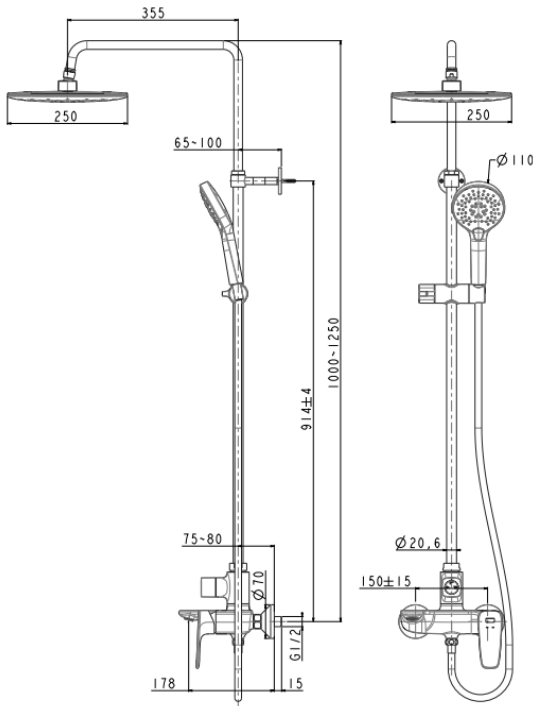

FEATURES

- A grade brass, strong and durable
 - Grohe High quality ceramic valve for longer usage
 - Ceramic cartridge tested = 500,000 times
 - With Ceramic 3-way diverter cartridge
 - With Rainshower kit
 - With 3F hand shower (air in)
 - With Easy-slide shower holder
 - With 1.5m Silver Twist-free shower hose
1. With normal packaging
- Flow rate @ 0.1MPa: 7.5 L/min for Spout
 - Flow rate @ 0.1MPa: 5.1 L/min for shower head
 - Flow rate @ 0.1MPa: 4.6 L/min for hand shower

SPECIFICATIONS

- Exposed Bath & Shower Mixer Faucet
- 2-Hole Installation: lever handle (cold & hot)

FINISHES AVAILABILITY

- Chrome (- CP)

AWARDS WON

- N/A

SHIPPING WEIGHT

- Product gross weight: 8.0kg /set
- Product net weight: 5.93kg /set

STANDARDS CRITERIA

- GB 18145-2014
- TIS 2066-2552