

Signature

American Standard

3 Hole Basin Mixer FFAS1703-1015L0BC0



FEATURES

- Low lead brass, strong and durable
- High quality ceramic valve for longer usage
- Ceramic cartridge tested = 500,000 times
- Neoperl aerator PCA 1.5 GPM
- With pop-up drain
- With normal packaging
- Flow rate @ 0.1MPa: 3.8 L/min for spout

SPECIFICATIONS

- Basin mixer faucet
- 3-hole installation: lever handle
- Spout reach: 104 mm
- Spout height: 103 mm

FINISHES AVAILABILITY

- Chrome (- CP)

AWARDS WON

- N/A

SHIPPING WEIGHT

- Product gross weight: 2.99kg /set
- Product net weight: 2.79kg /set

STANDARDS CRITERIA

- GB 18145-2014

DIMENSIONAL DRAWING

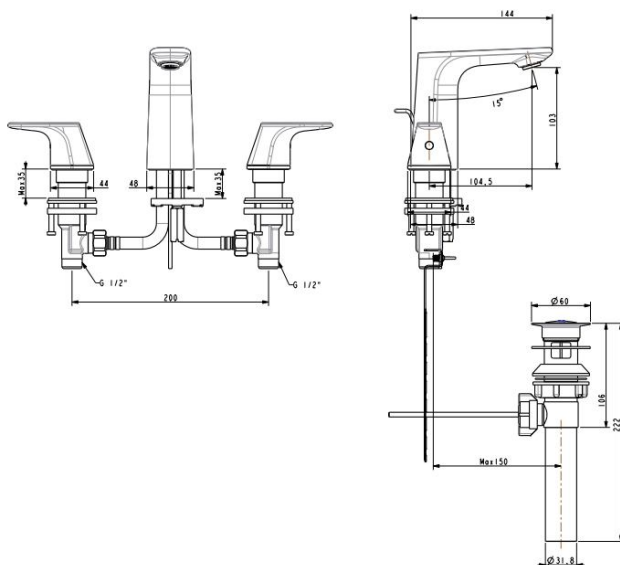

This document is the property of American Standard. It can neither be reproduced, nor communicated, without authorization.

American Standard reserves the right to change dimensions and specifications without notice, we assume no liability for the use of obsolete dimensions.