

American Standard

TemptaCion Auto Temperature Shower System (3-way) FFAS4952-601500BC0

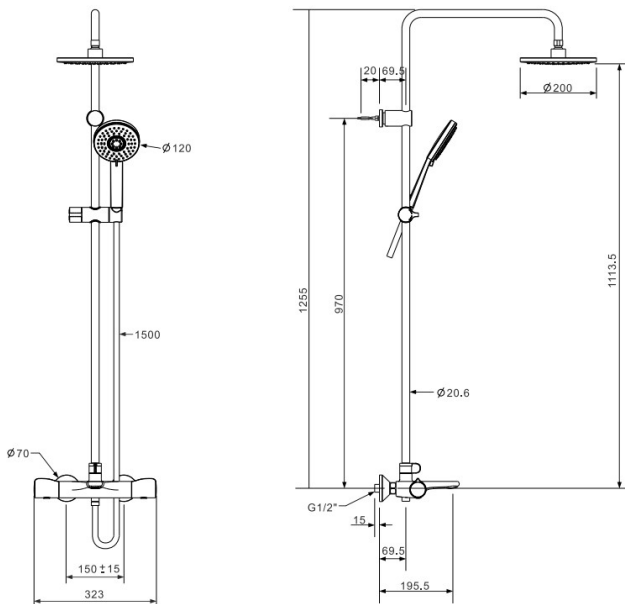

DIMENSIONAL DRAWING



FEATURES

- German thermostatic cartridge
- Cool touch design, no risk of scalding on the body
- High quality THM valve for utmost precision, with Anti-scald button
- Diverter with shut off function for longer usage
- Diverter with shut off function tested = 300,000 times
- Inline diverter for head shower and hand shower tested = 100,000 times
- Neoperl hidden flow regulator
- 5-functions hand shower
- The diameter of the head shower is 200 mm
- PVC Silver twist-free shower hose
- With easy glide shower holder
- With normal packaging
- Flow rate @ 0.1MPa: 4.6L/M for hand shower
- Flow rate @ 0.1MPa: 4.5 L/M for shower head
- Flow rate @ 0.1MPa: 15.2 L/M for Spout

SPECIFICATIONS

- Exposed THM mixed
- Two handles (THM handle & Shut off handle)
- Inline diverter to switch water to hand shower and head shower

FINISHES AVAILABILITY

- Chrome (- CP)

AWARDS WON

- N/A

SHIPPING WEIGHT

- Product gross weight: 8.06kg/set
- Product net weight: 6.26kg/set

STANDARDS CRITERIA

- QB 2806-2017